

Reverzná osmóza RUWA



POPIS PRODUKTU:

- 5-stupňové zariadenie
- Montážna súprava
- Inteligentná batéria s indikáciou stavu
- Vysokovýkonná membrána so samočistením (preplach)
- Integrovaný hydraulický okruh
- Jednoduchá údržba



TECHNICKÁ ŠPECIFIKÁCIA:

Rozmery: 410 x 132 x 335 mm

Hmotnosť: 12,5 kg

Prietok: 1,8 l/min.

Teplota (max./in.): 38 stupňov/5 stupňov

Vstupné TDS (max.) : 1500 ppm

Tlak: 4-1 bar

Membrána: 600 GPD

Čerpadlo: Booster

Napájanie: 24 V, 96 W

Externý adaptér: 100-240 V AC, 50/60 Hz, 4A

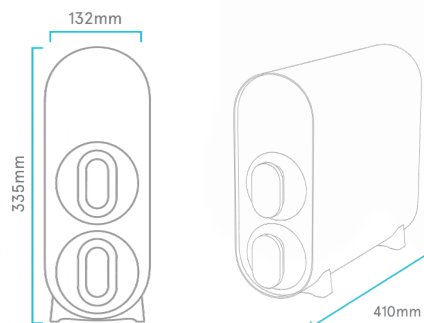

WLG (B-60326279), is member of the Water Quality Association.



ENAC
Certif. nº 34/5200/14/0712

The trading of water treatment and household appliances as well as designing and teaching of non-official training courses related with its technology are certified and comply with the UNE-ISO-9001 for WLG (B-60326279).



WLG (B-60326279) is an Aqua España member, who belongs Aqua Europa (Federation of European nation associations).



WLG (B-60326279), has the rights granted for Authorized Economic Operator with number ESAEOF1800008U6 and 13/02/2018 as a date of entry of the authorization.